

Introducing the **AirFlex™** Portable Trim Waste + Dust Containment System



The AirFlex with independent pedestal mounted controls + standard dust containment



Introduction

As speeds of converting equipment increase, the need for effective trim waste removal escalates. Specify the **AirFlex** for effective trim waste handling to help optimize converting and printing production rates.

You may have started out small, but you have always thought big. You have been waiting for this pneumatic trim waste removal system. It will fit your plant, your product mix (paper, plastic, film or foil), your production (batch or continuous), your ambition and your budget. It needs to be small, powerful, easy to use, and tough **but most important of all flexible... to help you this year and for years to come.** The AirFlex is exactly the pneumatic trim waste removal system you have been waiting for. We offer affordable purchase or rental options.

Because it's flexibility can help you in so many ways

- For paper, plastic, film and foil converting operations, up to 1000 fpm
- For both office and shop environments
- For both batch and continuous converting operations
- For both small and large size companies
- For bag, cart, and gaylord disposal options
- For both portable and stationary applications
- Adaptability to easily modify both standard intake and discharge features to accommodate future (unknown) production demands



1701 Dalton Dr, New Carlisle, OH 45344
sales@airtrim.com - 888-247-8746
AirTrim.com

1701 Dalton Dr. • New Carlisle Ohio 45344
Tel : (888) 247-8746
Email: sales@airtrim.com
www.airtrim.com

AirFlex™ since 1989

Good things come in small packages

- Compact 36" wide x 116" long design optimizes valuable floor space.
- Standard 106" assembled canister filter height (removable) fits under 9' office ceilings.
- Weight of approx. 500 lbs allows easy portability to accommodate changes in production equipment layout.
- Low decibel readings maintain acceptable sound levels for employee work areas.
- Standard powder-coated enclosure is both office attractive and production tough.

AirFlex was designed with operators in mind

- Rugged, proven 1½ HP Trim Cutter, coupled with tested 5 HP material handling fan
- Capacity of (2) trims up to 2 ¼" wide, minimum thickness .0004", up to 1000 fpm line speed
- Basic components proven in hundreds of application world wide
- Rugged steel fabricated manual diverter easily handles paper, plastic, film and foil trim waste
- (4) wheel cart design allows easy maneuverability over roughest floor surface
- Easy clean canister dust filters
- Twin bag waste discharge or tilt cart or Gaylord disposal

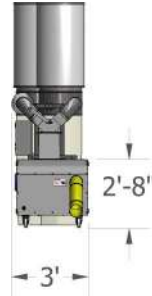
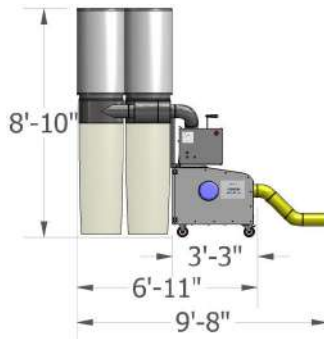

Check out these AirFlex ROI Benefits

- Eliminates trim waste removal production delays; helps keeps converting and printing equipment running up to 1000 fpm
- Eliminates need for high energy cost compressed air often required for older trim removal systems
- Reduces trim waste volume up to 3/4; cuts costs of trips to landfill
- Facilitates recycling; easily separates material at source
- Specifically designed dust capturing to keep dust in bags, not on your finished product
- Standard plastic bag of 71 gallons (9.6 cu ft) of cut trim material; plus one option for larger bag:

Discharge height	Cubic Ft / bag	Gallons/ bag
53" (std)	9.6	71
68" (opt)	12	93

Intro AF 2023