

In pneumatic conveying systems, an air material separator separates conveyed material from conveying airflow. They are designed to minimize the amount of air exiting down with the discharged material. Plus, separators minimize back pressure to the conveying venturi or fan system. Exhausting air can be filtered through filters or mechanical means to insure a cleaner, lower dust workplace.

Separators are used extensively in the paper, film, foil and converting industries to separate conveyed material of waste material handling systems. The same separator designs are increasingly used as Pre-Separators in a wide variety of dust handling systems to improve efficiencies of dust handling systems.

AirTrim's CB (Curved Back) separator is our most popular model and has been our standard for more than 20 years. It is proven, rugged and requires minimal maintenance. The Low-Profile CB Series Separator offers one of the lowest installation heights in the industry; it often can accommodate a complete separator and baling system under the lowest ceiling heights.

The CB Series can fit either inside or outside your building

AirTrim offers the CB Series in three standard design capacities: CB 39, CB 78 and the CB 118. Each boasts a high material throughput and reliability in a compact design. AirTrim begins the design of each separator on one of these three starting points. Final design depends on the specific air flow and material parameters.





As shown in the diagram below, we have designed each of these CB capacities to be as compact as possible to achieve required CFM air flows to fulfill its design requirement. For systems requiring smaller or larger capacities, we will design a specific separator to provide the needed capacity for your application.

Model	Inlets	CFM	Height	Width	Length	Weight
CB39	2	5,000	48"	44"	44"	2,000 lbs.
SB 78	4	11,000	60"	75"	70"	3,000 lbs.
SB 118	8	22,000	120"	100"	90"	4,000 lbs.

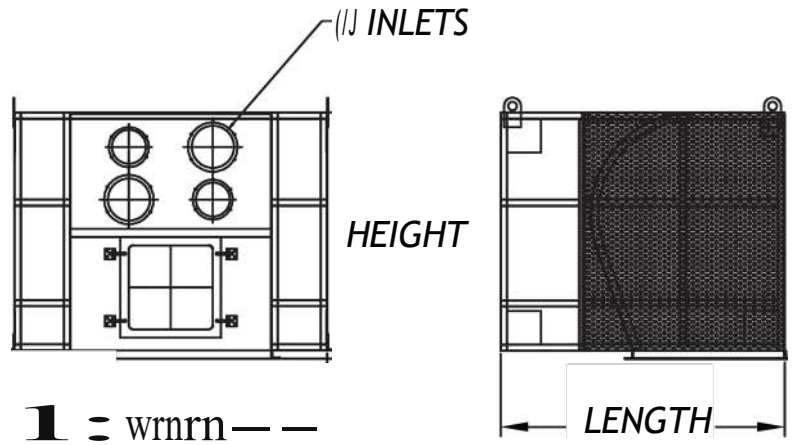

**Additional options to consider include:**

- Support Structure
- Outdoor Skin
- Dust Free Skin
- Interior special treatment for PSA (Pressure Sensitive Adhesive)

Looking for the best Separator in the industry?  
**Contact AirTrim for your Free Estimate!**  
[sales@airtrim.com](mailto:sales@airtrim.com) or call **1-888-247-8746**

AT Curved SEP 2023